

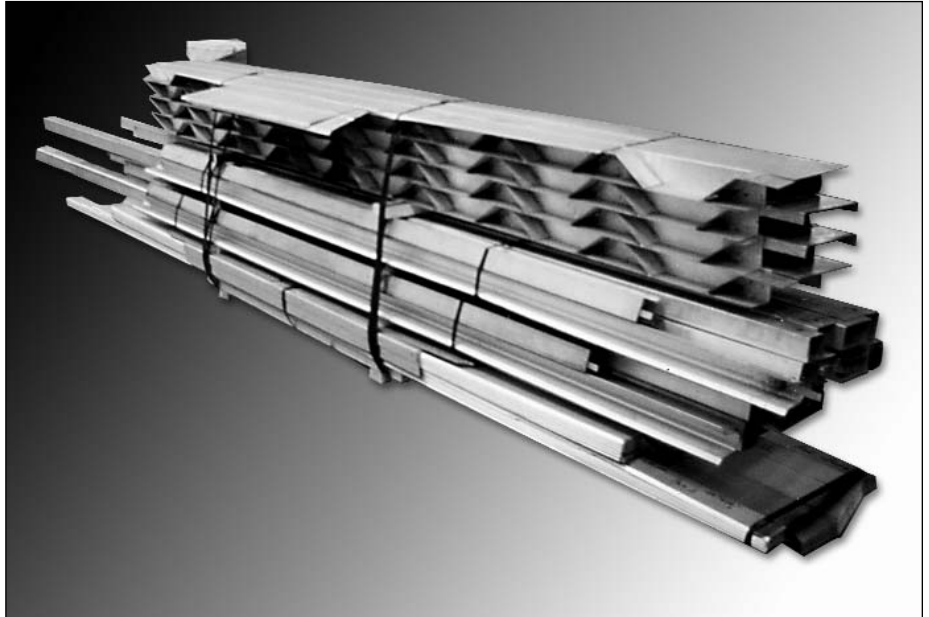


# Sliding Door Instructions

## Table of Contents

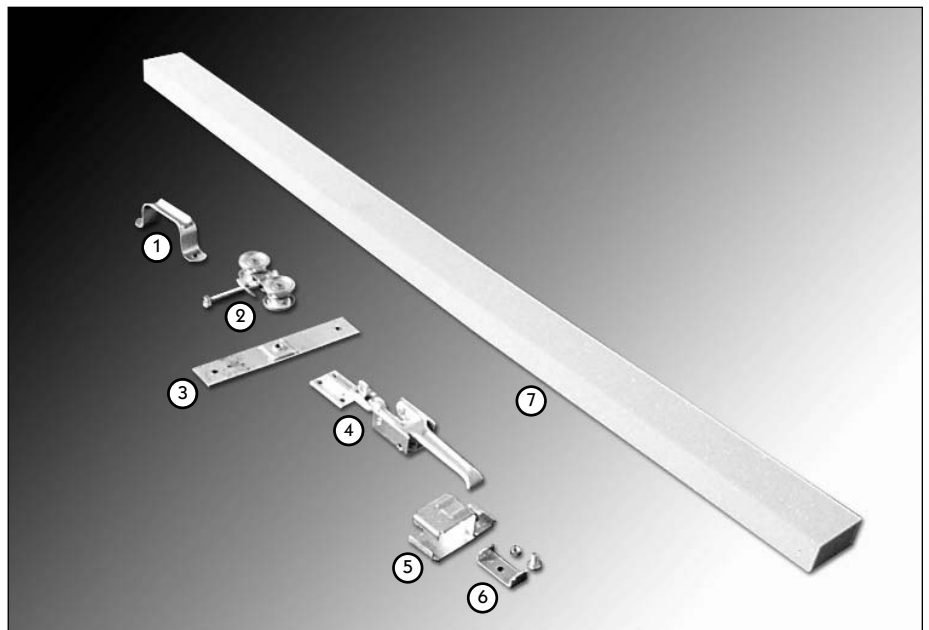
I. Sliding Door Parts . . . . .	.2
II. Installing Door Jamb & Stiffener . . . . .	.4
III. Header Beam Assembly . . . . .	.5
IV. Building Header Beam & Door Track . . . . .	.6
V. Header Support Posts . . . . .	.8
VI. Sliding Door Assembly . . . . .	.9
VII. Standing Door . . . . .	.14
VIII. Door Locks & Handles . . . . .	.15
IX. Installing Rain Shedders . . . . .	.16
X. Grouting Door Track . . . . .	.17

# I. Sliding Door Parts

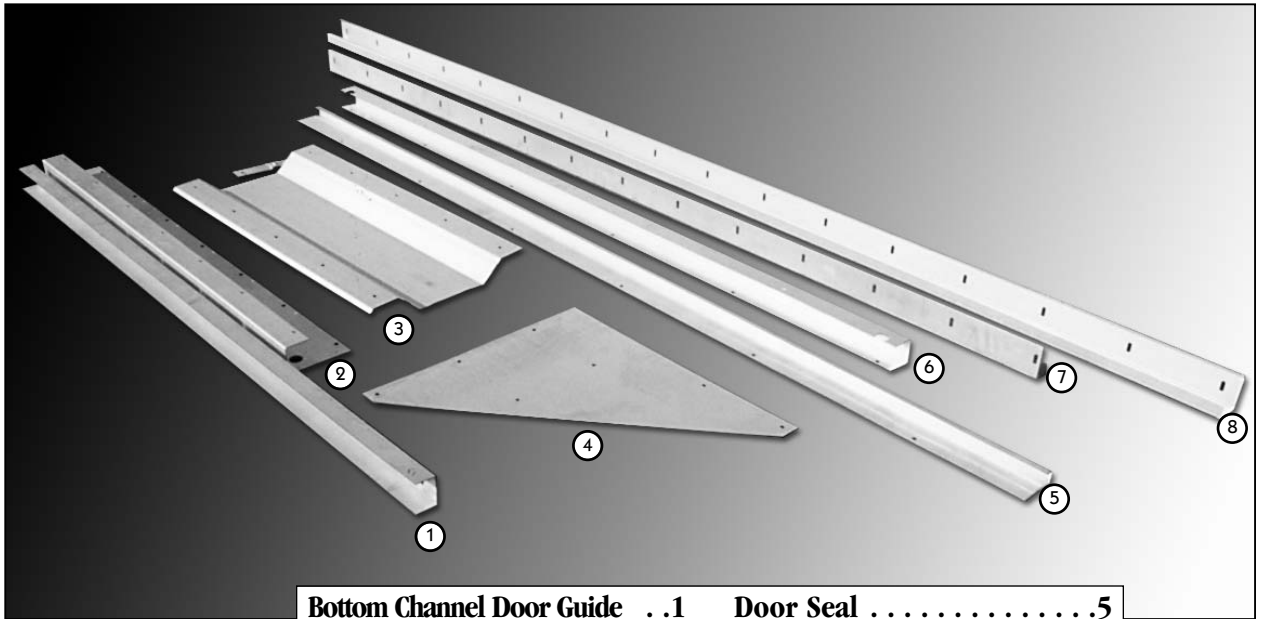


This is a 14" tall by 16" wide sliding door with both end-walls neatly packed for delivery.

- Door Handle** .....1
- Roller** .....2
- Roller Bracket** .....3
- Door Lock** .....4
- Track Bracket** .....5
- Track Joiner Clip** .....6
- Foam Stuffer** .....7

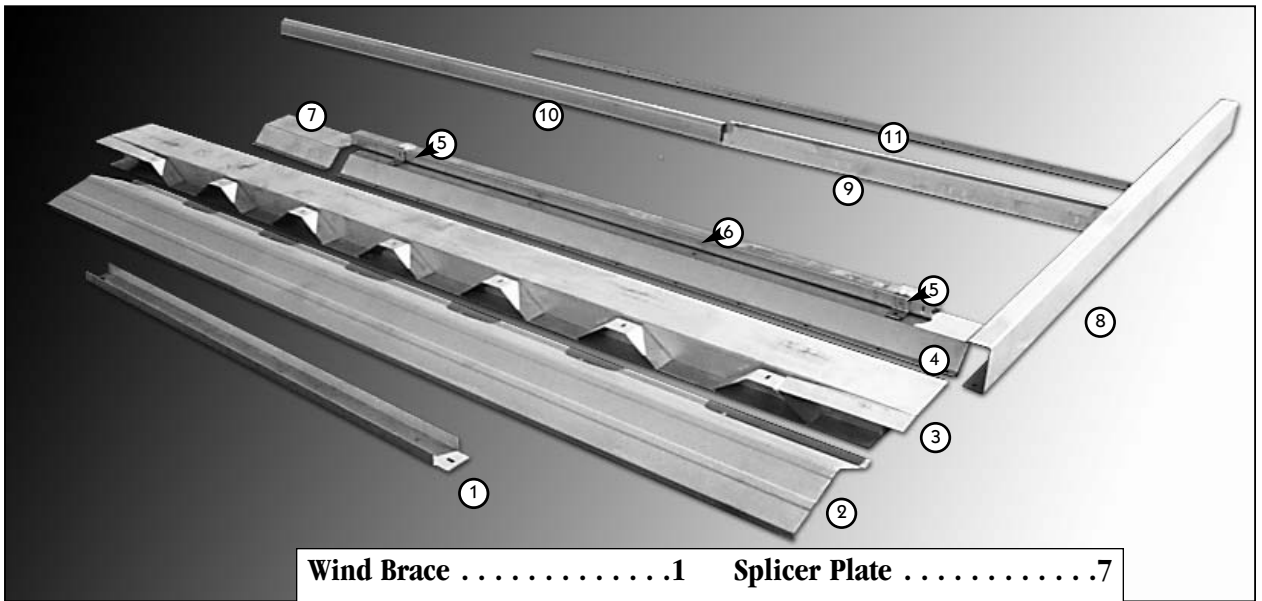


# I. Sliding Door Parts (continued)



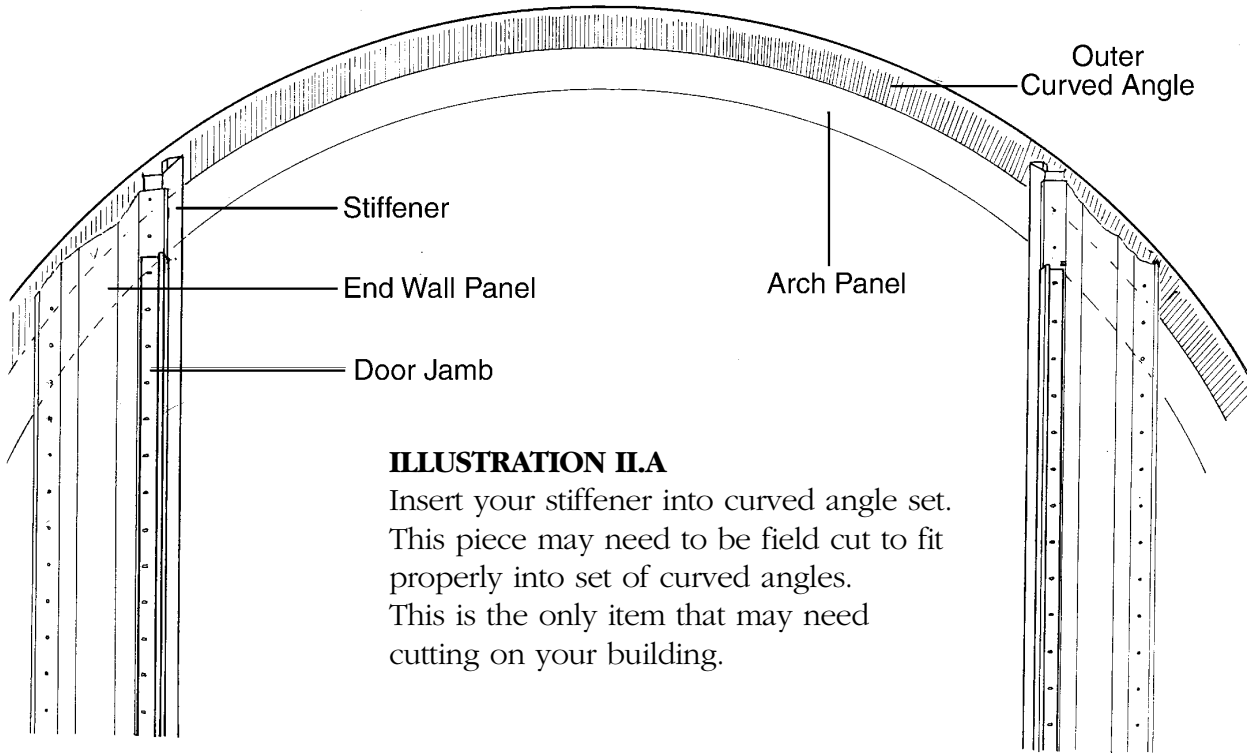
<b>Bottom Channel Door Guide . . .1</b>	<b>Door Seal . . . . .5</b>
<b>Top/Bottom Door Channel . . . .2</b>	<b>Vertical Door Channel . . . .6</b>
<b>Door Panel . . . . .3</b>	<b>Door Jamb . . . . .7</b>
<b>Optional Plate* . . . . .4</b>	<b>Stiffener . . . . .8</b>

\* Only included when connector beam is not used.



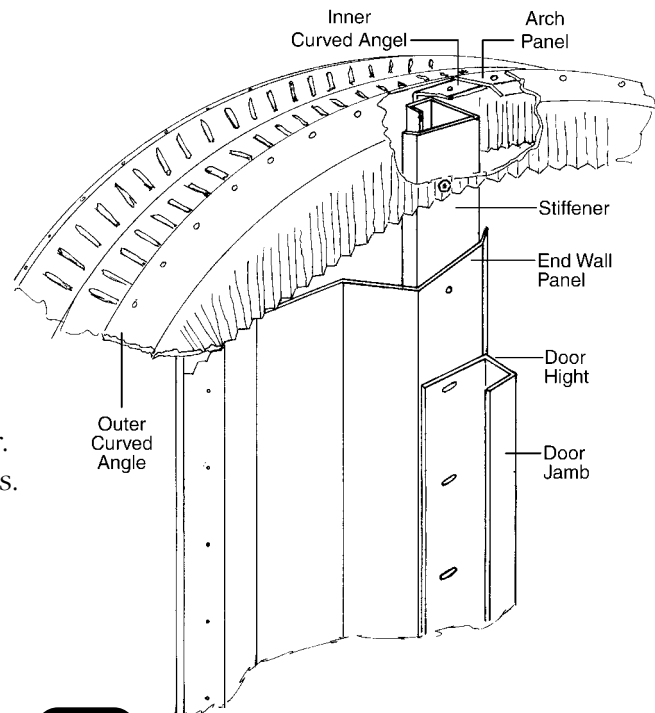
<b>Wind Brace . . . . .1</b>	<b>Splicer Plate . . . . .7</b>
<b>Rain shedder . . . . .2</b>	<b>Header Support Post . . . . .8</b>
<b>Overhead Door Connector . .3</b>	<b>Outer Door Guide . . . . .9</b>
<b>Header Beam . . . . .4</b>	<b>Inner Door Guide . . . . .11</b>
<b>Track Bracket . . . . .5</b>	<b>Arch &amp; Endwall Strapping .12</b>
<b>Door Track . . . . .6</b>	

## II. Installing Door Jamb & Stiffener



### ILLUSTRATION II.A

Insert your stiffener into curved angle set. This piece may need to be field cut to fit properly into set of curved angles. This is the only item that may need cutting on your building.



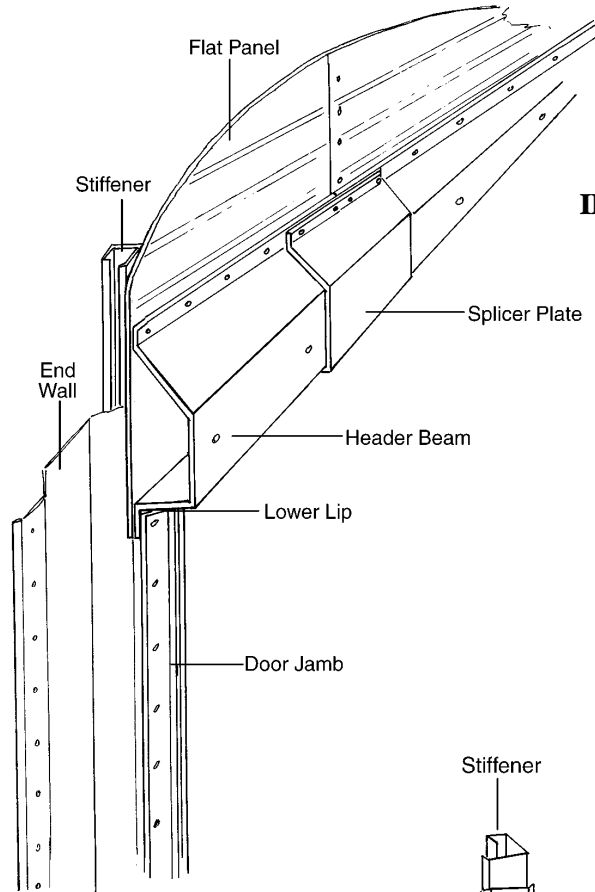
### ILLUSTRATION II.B

Install door jamb before inserting bolts through endwall into stiffener. Same bolt goes through all 3 pieces. Leave top 4 bolts out until header beam is installed.

### III. Header Beam Assembly



If opening above door is less than 33", flat panel instead of corrugated end wall panel will be supplied.

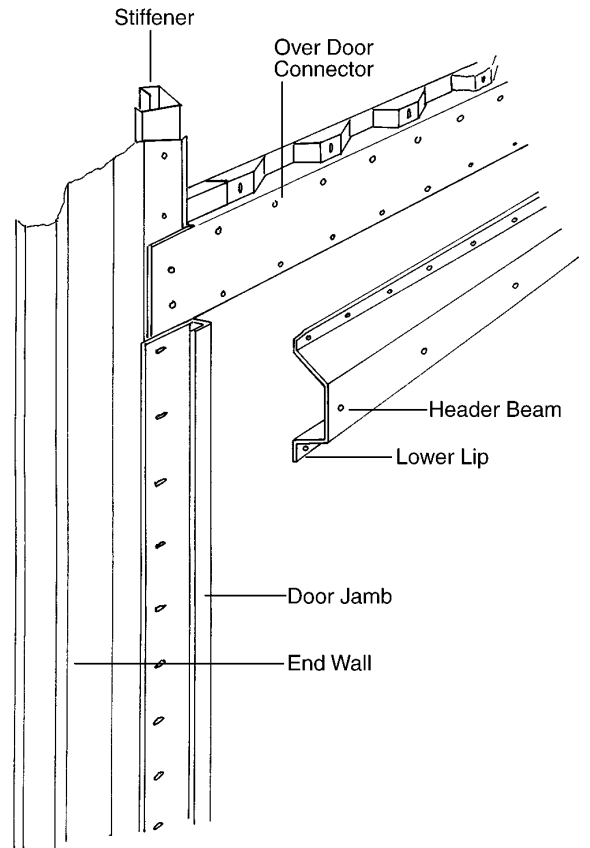


**ILLUSTRATION III.A**



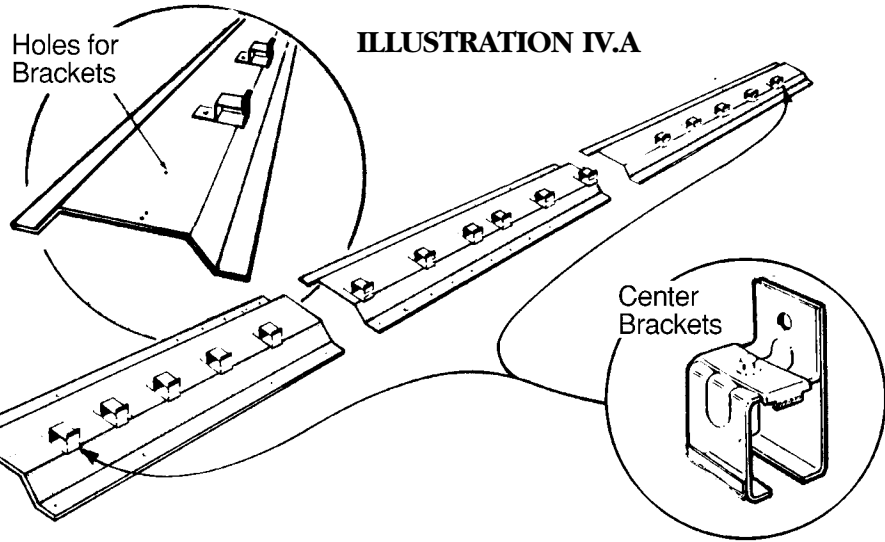
See Illustrations III.A & III.B to determine which applies to your specific building, then complete header as follows in the pertinent page.

**ILLUSTRATION III.B**



## IV. Building Header Beam & Door Track

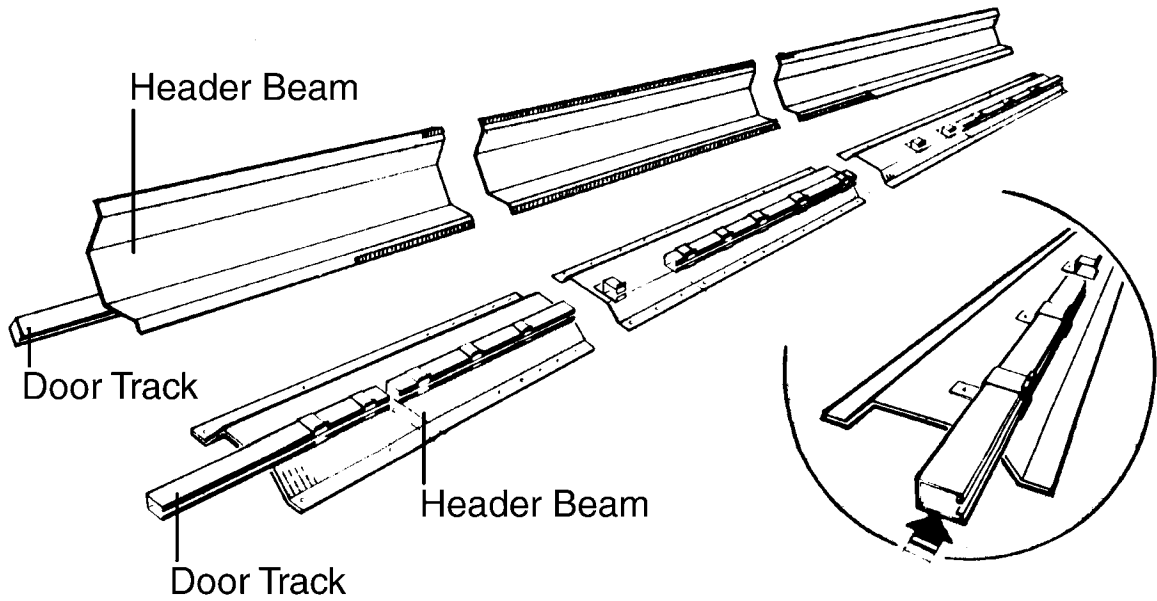
ILLUSTRATION IV.A



The brackets should now be fastened to the sections of header beam.

Use splicer plates to join sections of header.

ILLUSTRATION IV.B

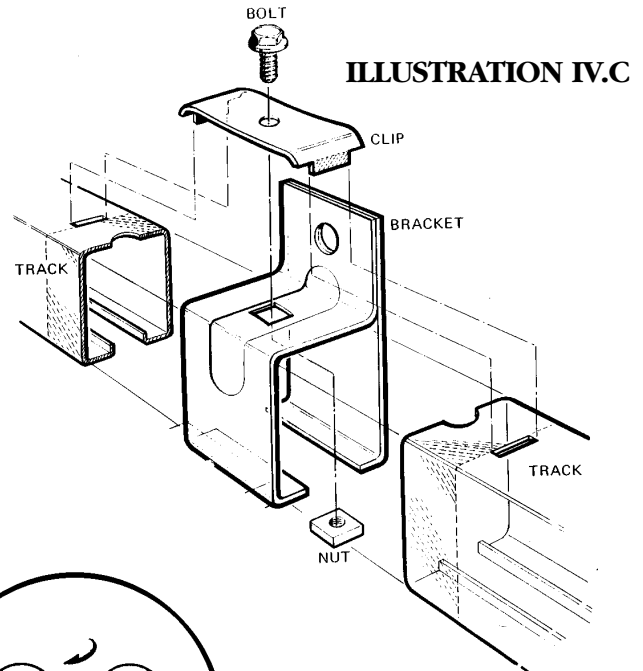


The door track should now be fed into the brackets.

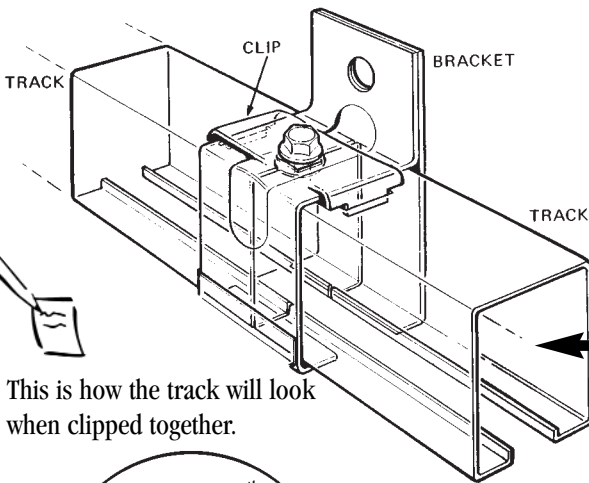


## IV. Building Header Beam & Door Track (continued)

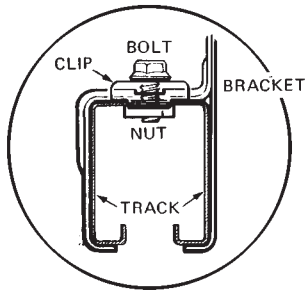
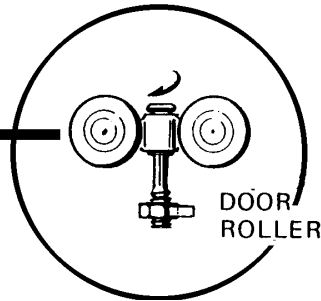
Once the track is in place the sections should be fastened together using the clips found in the hardware box. One clip is required at each joint of the pieces of track.



**ILLUSTRATION IV.D**

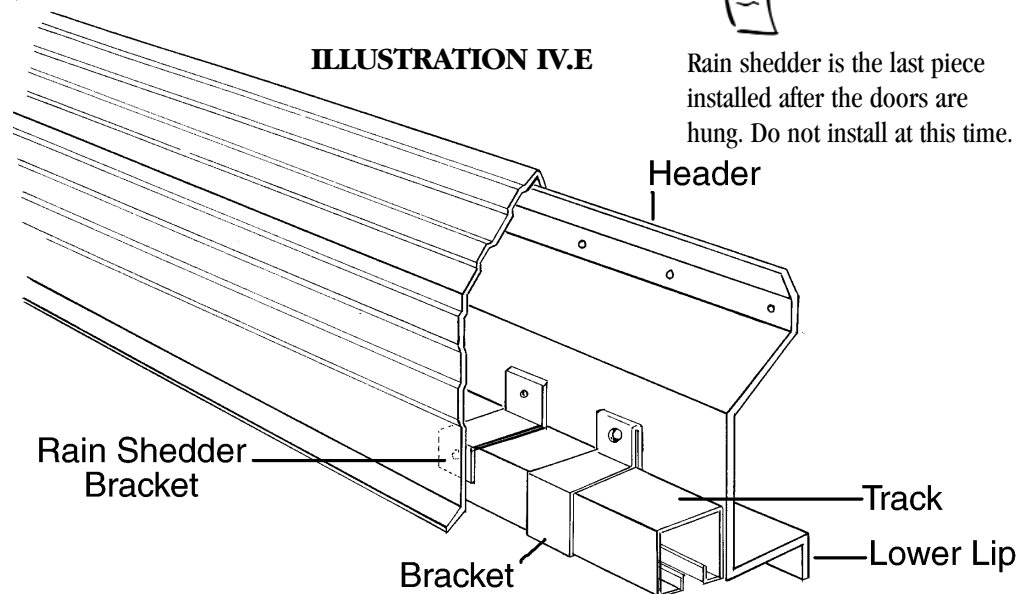


This is how the track will look when clipped together.



**ILLUSTRATION IV.E**

Rain shedder is the last piece installed after the doors are hung. Do not install at this time.



Use self drilling screws to fasten Rain shedder to header.

## V. Header Support Posts

These posts are attached to heaper on ground. Raise the heaper once you have your scaffolding in place. The lip of the heaper will be placed between the endwall & door jamb.



The header support posts should now be bolted into the ends of the header beam.

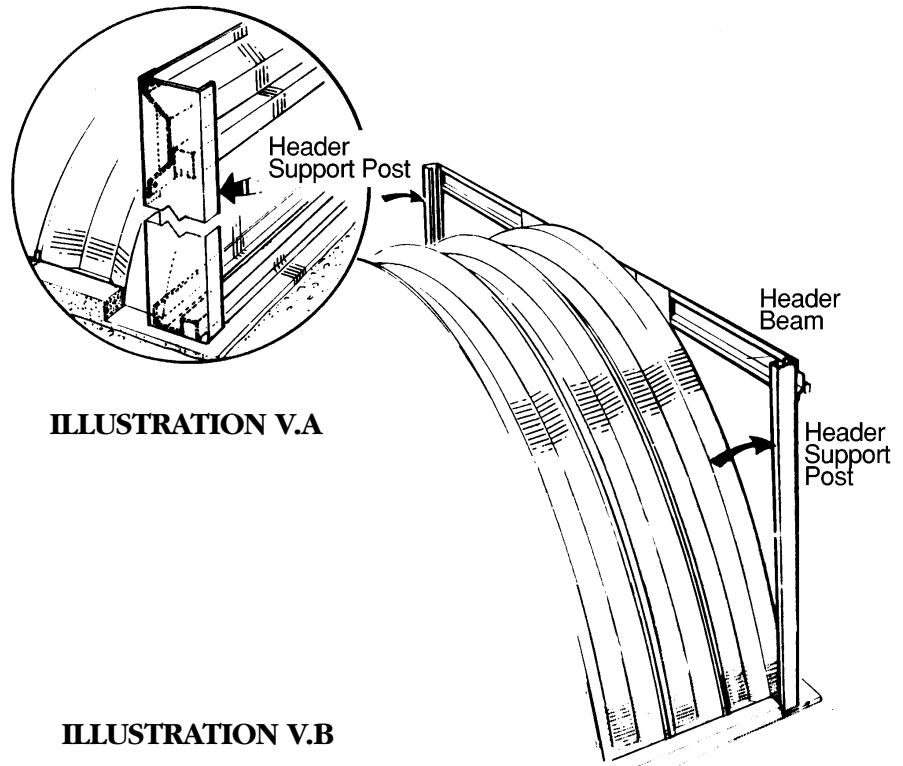
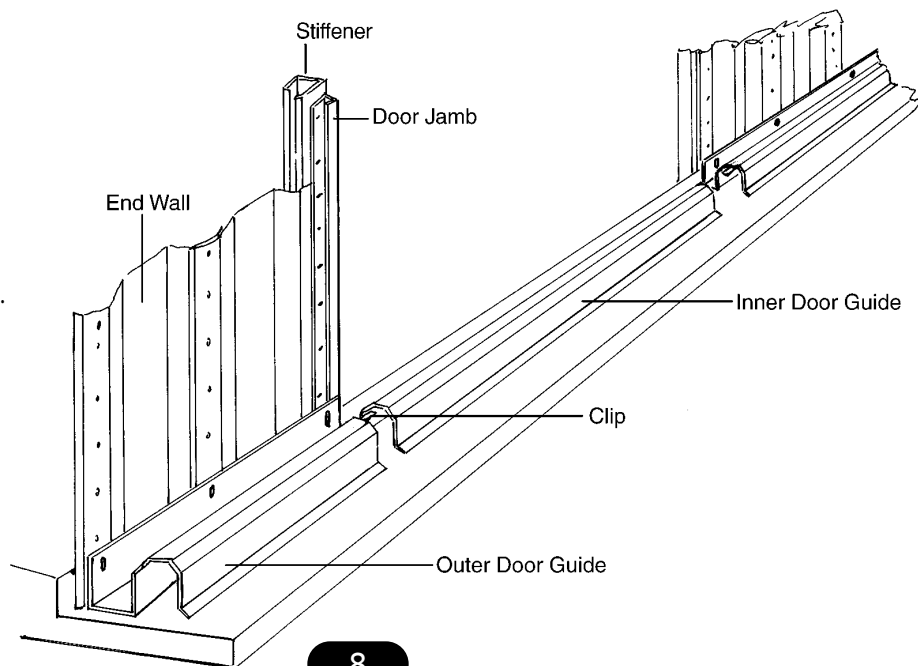


ILLUSTRATION V.A

ILLUSTRATION V.B



At this time bolt your outer door guides to the endwalls the inner guide is not installed at this time.



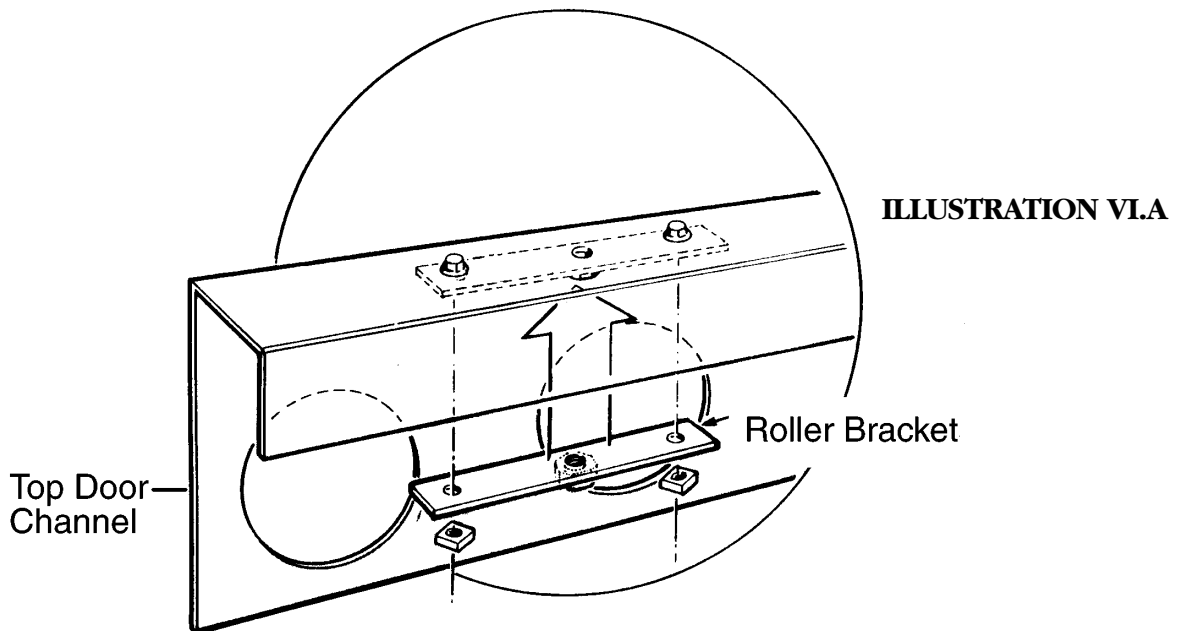
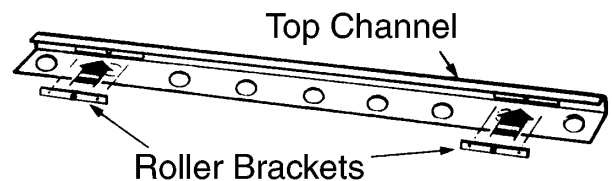
## VI. Sliding Door Assembly

The door arrangement in this building is basically a two section sliding door. The doors should be assembled off the ground preferably on wooden horses. This is to allow a man to reach underneath the door when assembling.

The first stage is to familiarize yourself with all the door components. The large blow-up on the preceding page clearly shows all the door parts, their names and part numbers. Study this drawing and familiarize yourself with every part before you attempt to assemble the doors.



The roller brackets, found in the hardware box should be bolted onto the top door channel as shown.

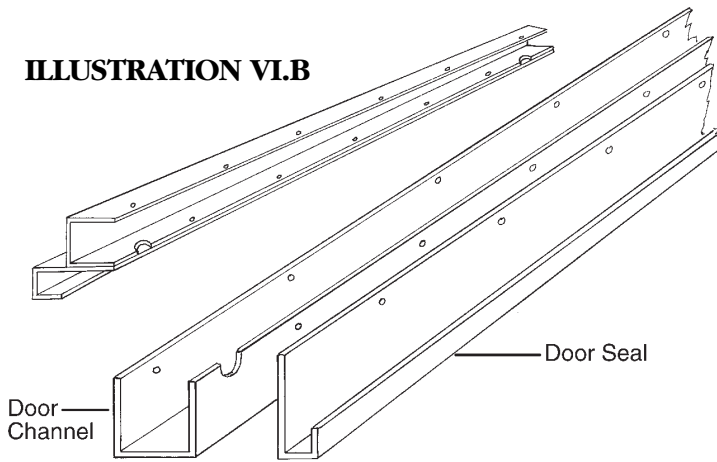


## VI. Sliding Door Assembly (continued)

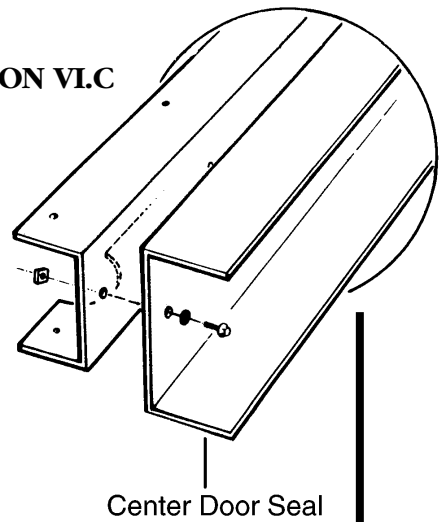
The side door seal is bolted onto the vertical door channel for both doors.

The center door seal channel is bolted to one of the vertical door channels.

**ILLUSTRATION VI.B**

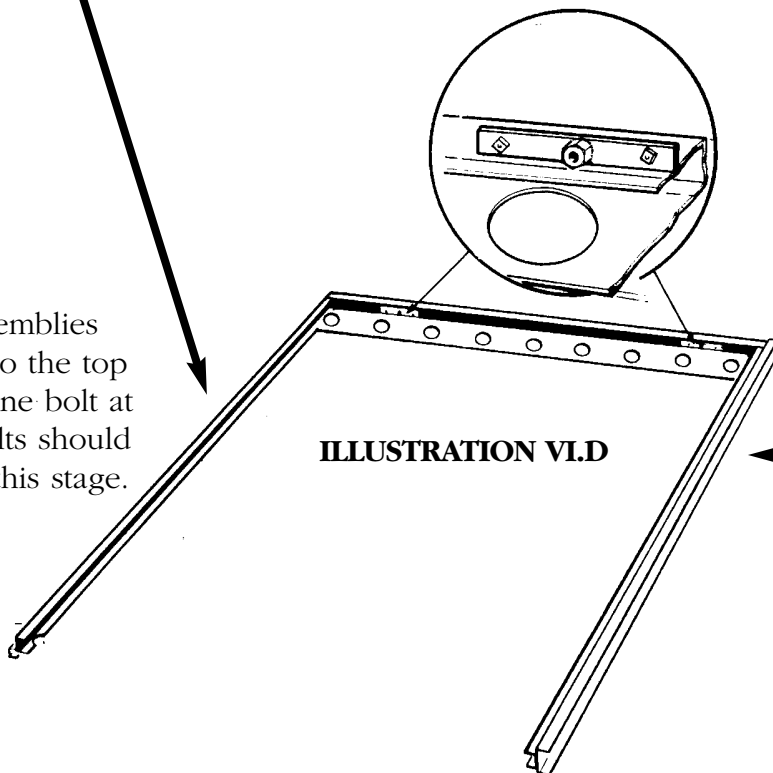


**ILLUSTRATION VI.C**



The two vertical assemblies should be fastened to the top door channel with one bolt at each corner. The bolts should not be tightened at this stage.

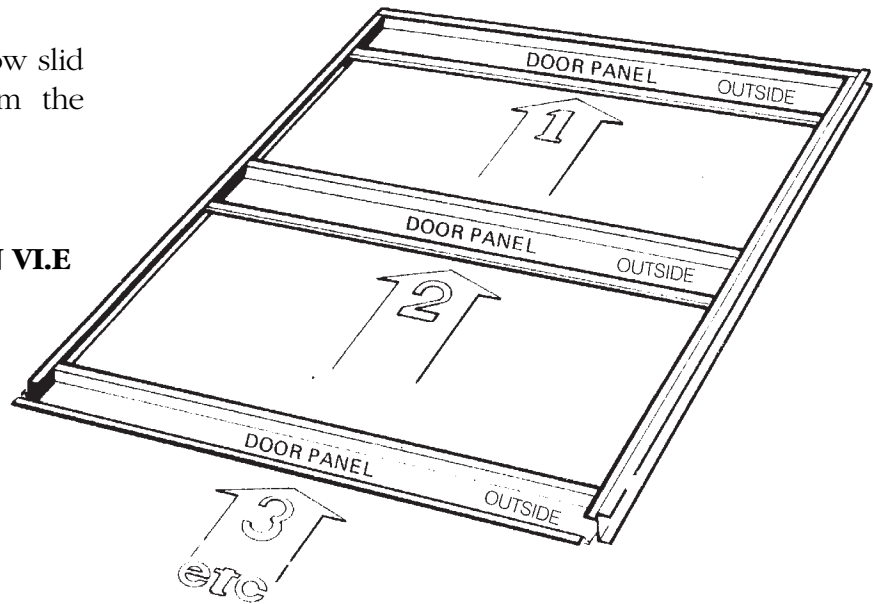
**ILLUSTRATION VI.D**



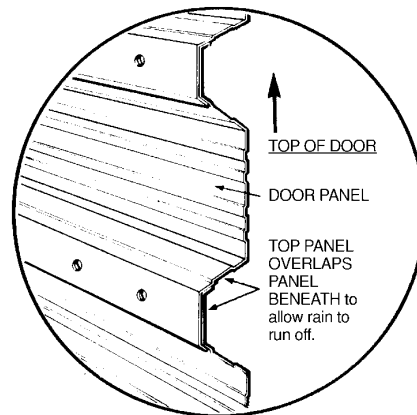
## VI. Sliding Door Assembly (continued)

The door panels are now slid into this framework from the bottom as shown.

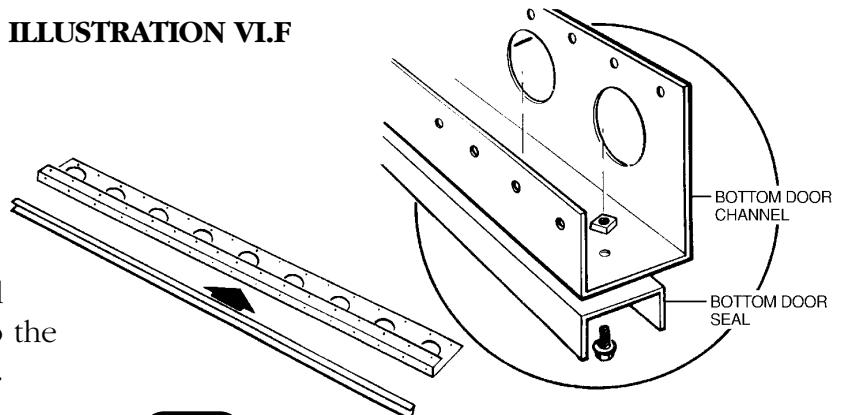
**ILLUSTRATION VI.E**



The panels should be lapped in such a way as to allow rain to run down the door easily. Each panel should be slid up and tapped under the panel above.



**ILLUSTRATION VI.F**

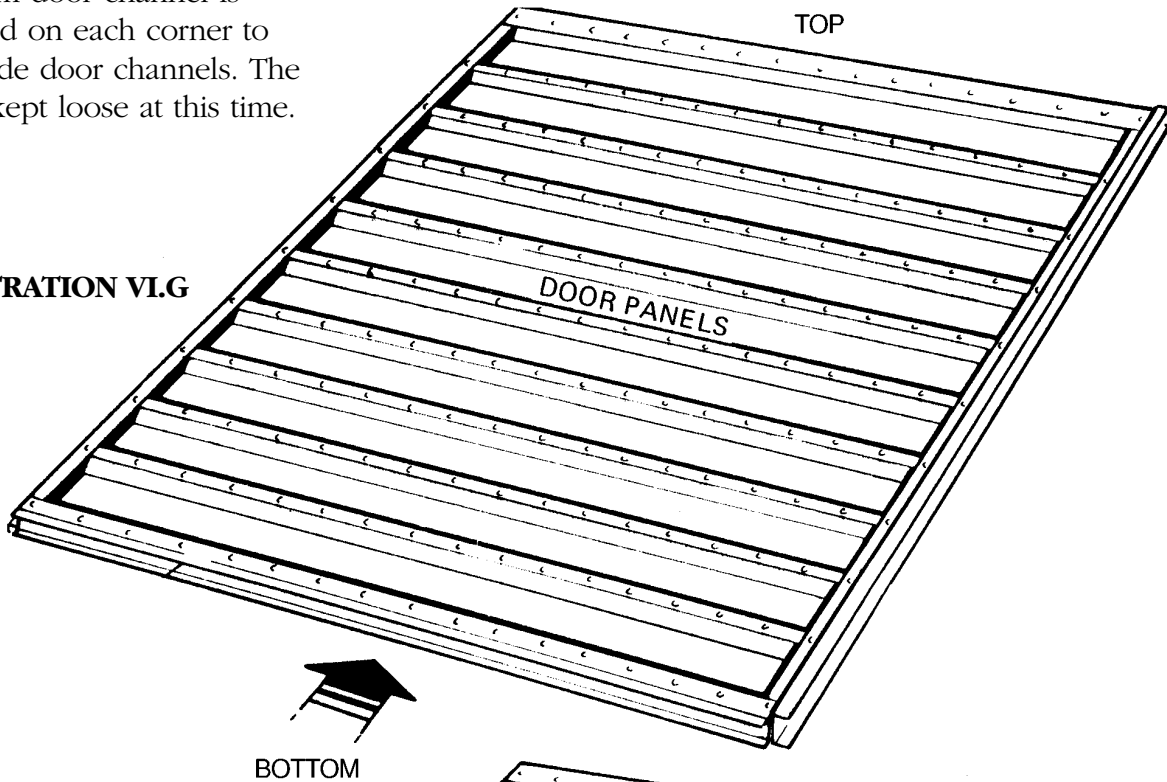


The bottom door seal should be bolted into the bottom door channel.

## VI. Sliding Door Assembly (continued)

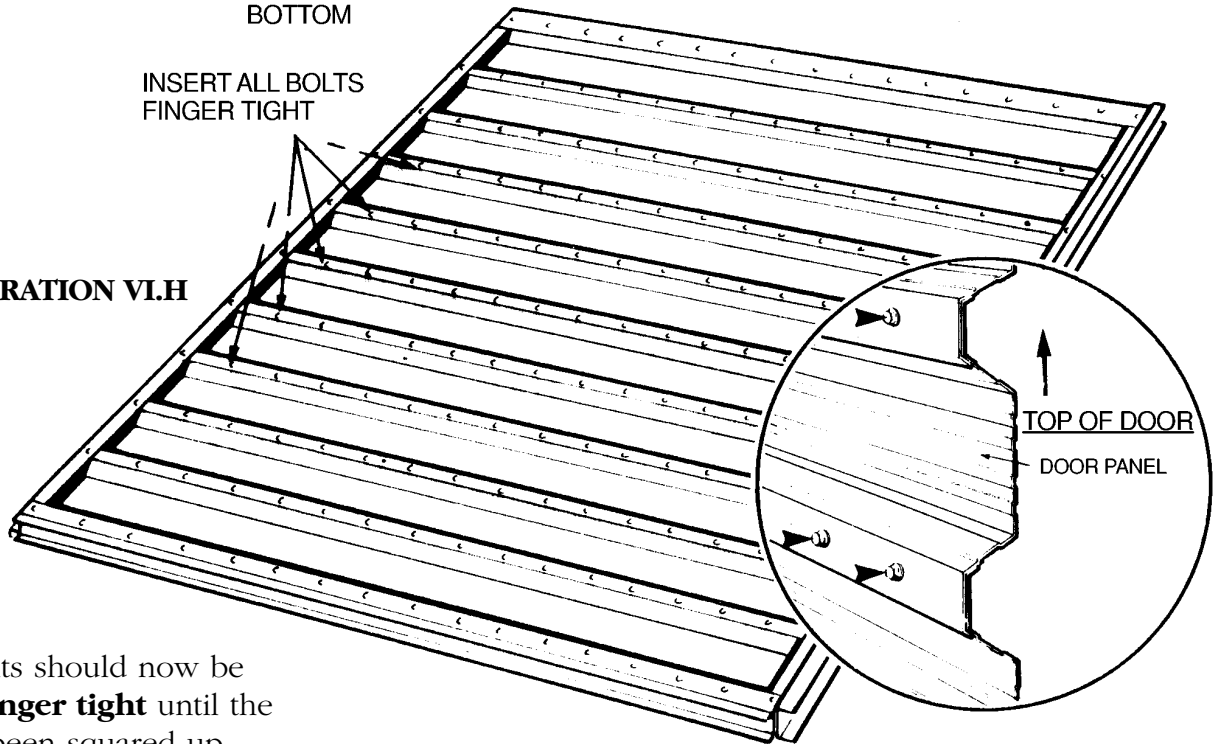
The bottom door channel is now bolted on each corner to the two side door channels. The bolts are kept loose at this time.

ILLUSTRATION VI.G



INSERT ALL BOLTS  
FINGER TIGHT

ILLUSTRATION VI.H



All the bolts should now be inserted **finger tight** until the door has been squared up. Square door and tighten bolts.

## VI. Sliding Door Assembly (continued)



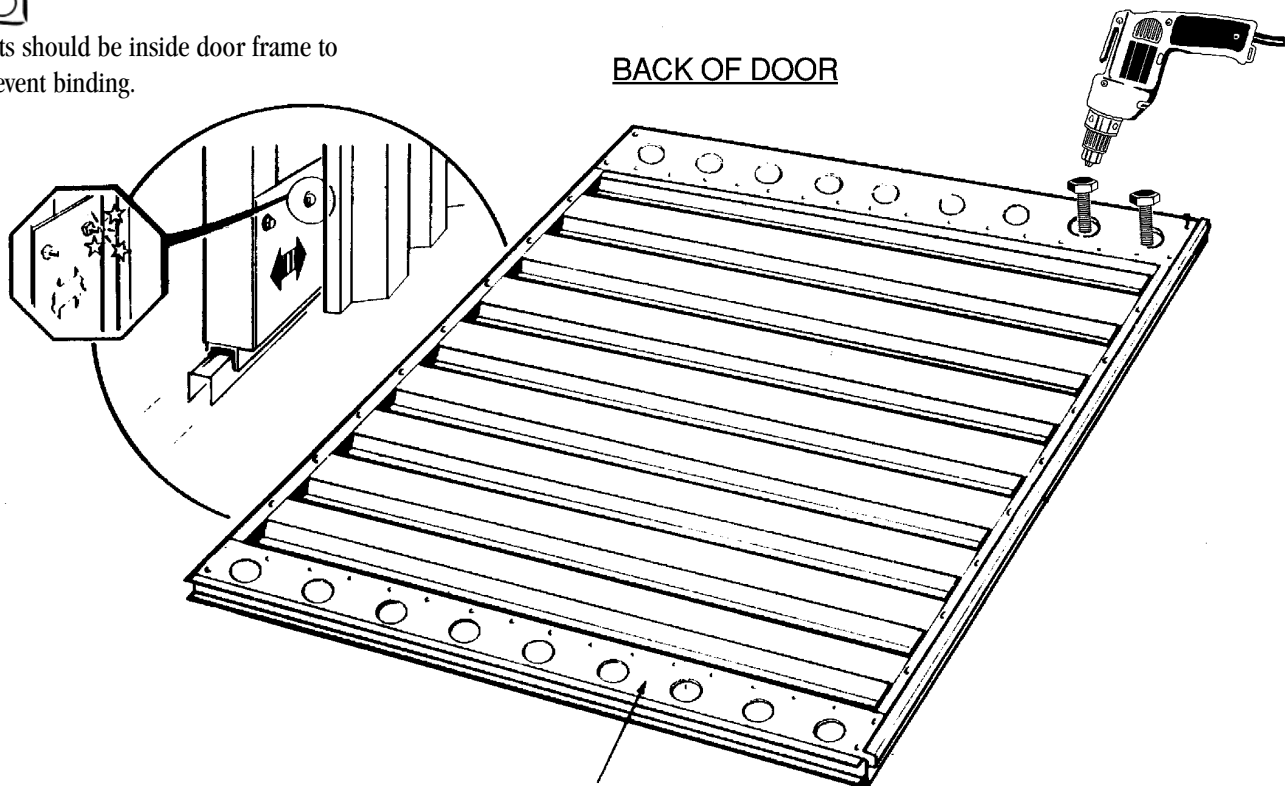
The bolts should be inserted with the heads to the inside of the building. This prevents the bolts from hitting on the door jamb.



Nuts should be inside door frame to prevent binding.

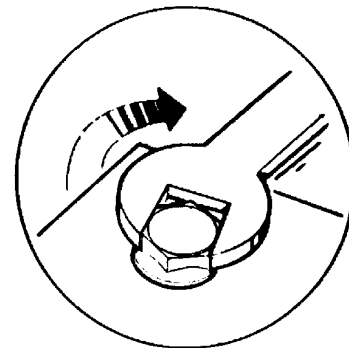
The door should now be turned over and holes drilled through the door panels using the holes in the back of the top and bottom door channels and the vertical door channels as templates. Bolts should be inserted into these holes and tightened up.

The other half of the door is assembled in the same manner except the center door closure is not needed (only 1 center door closure is required).



Turn the door over and tighten the frame bolts connected.

ILLUSTRATION VI.I



## VII. Standing Door

Stand door in opening, raising the door 2 to 3 inches to align with your threaded rod on your rollers that are located in your door track. The easiest way to accomplish this is with a crow-bar and 2 x 4 for leverage. After attaching all 4 rollers, it may be necessary to adjust the rollers up or down so that the door is hanging level and running smoothly. After adjusting the level of the doors, the lock nut must be tightened.

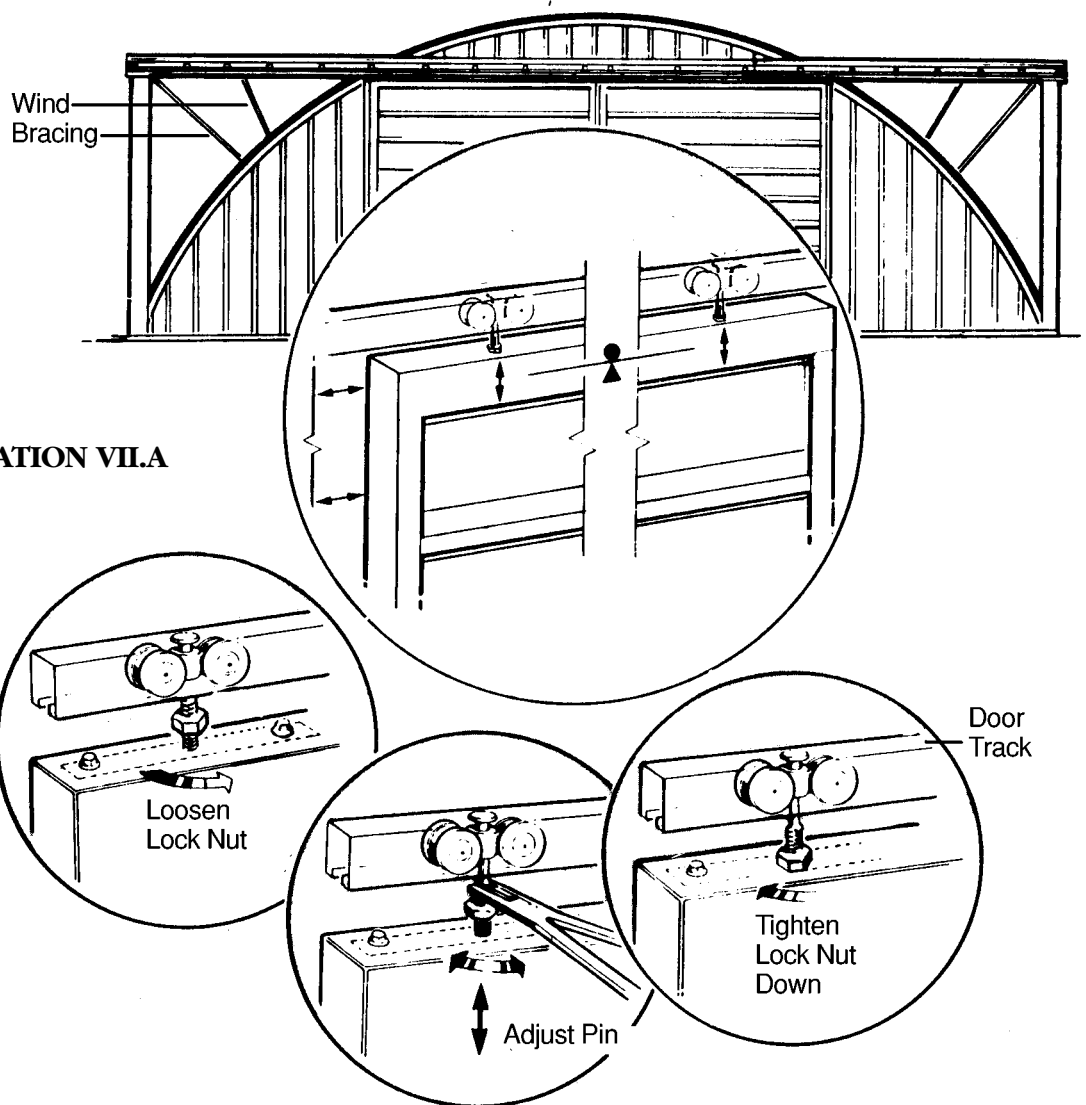
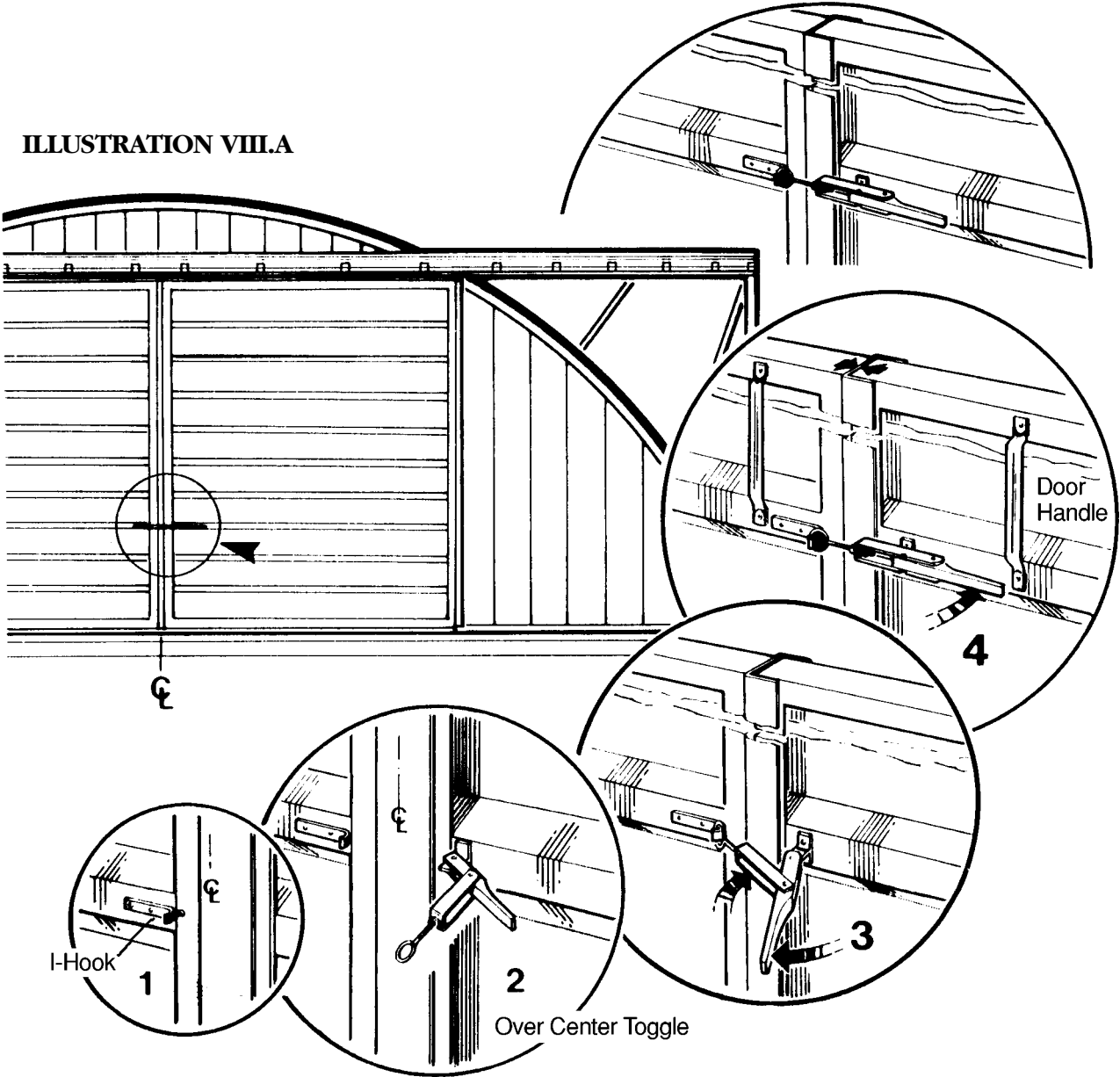


ILLUSTRATION VII.A

# VIII. Door Locks & Handles

With the door in the closed position, the door latch is attached as shown. Holes are drilled through the door and the two parts of the latch bolted into place. The door handles can be placed at your convenience by drilling holes through the door at a height convenient for you and then bolting them.

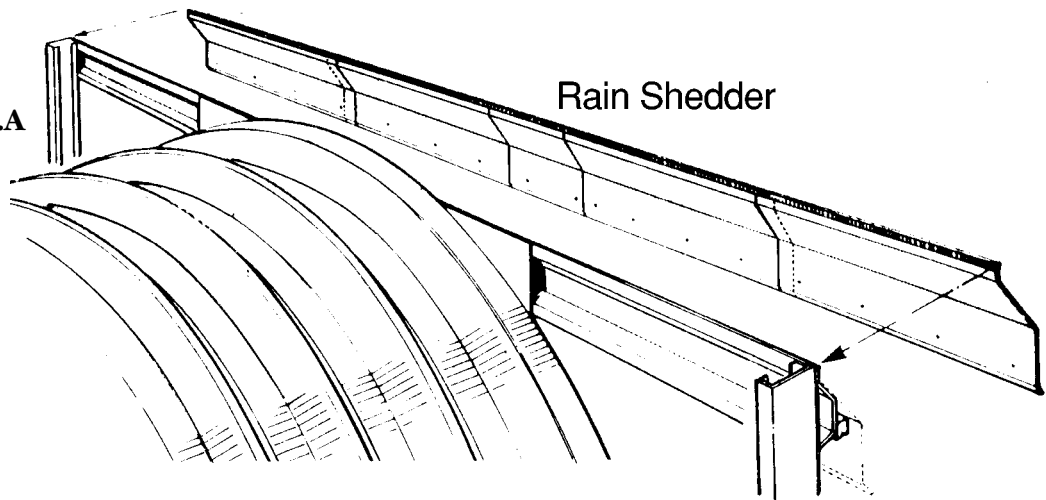
ILLUSTRATION VIII.A



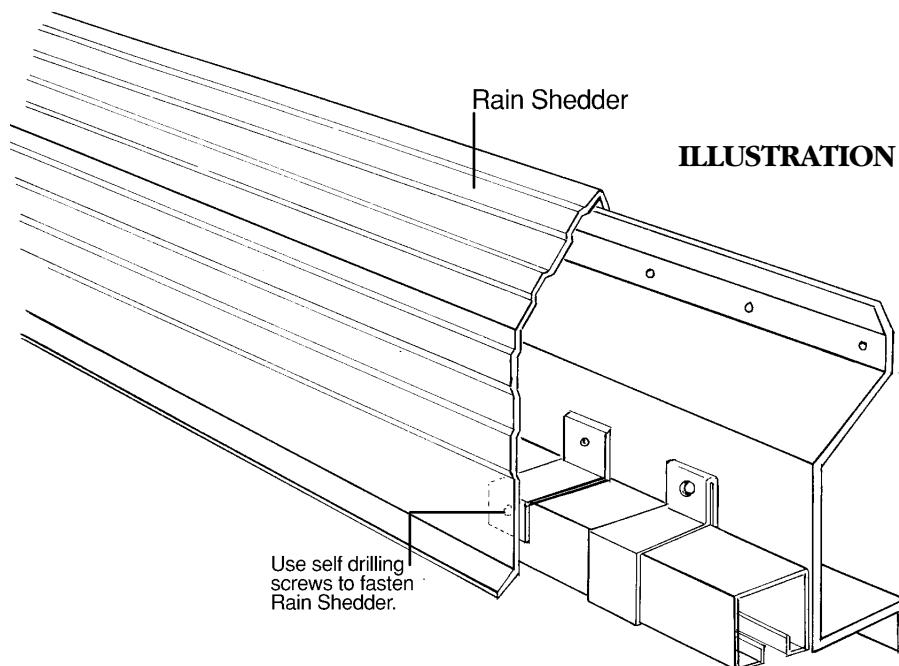
## IX. Installing Your Rain Shedder

Except for grouting this endwall is completed, and you can go on to install the solid endwall. It is advisable to leave the front doors open until the solid end is completed. This allows any high winds to pass through the structure relatively unobstructed.

ILLUSTRATION IX.A



Some caulking will be required above door opening, use only clear silicone caulking that can be bought at your local hardware store.



---

## X. Grouting Door Track

It is now time to grout your endwall and door track into place. Take your inner door guide and fill with grout. Hang your inner door guide on the metal clip that are attached to the outer door guide and finish grouting inner door guide at a gradual slope covering entire footer.

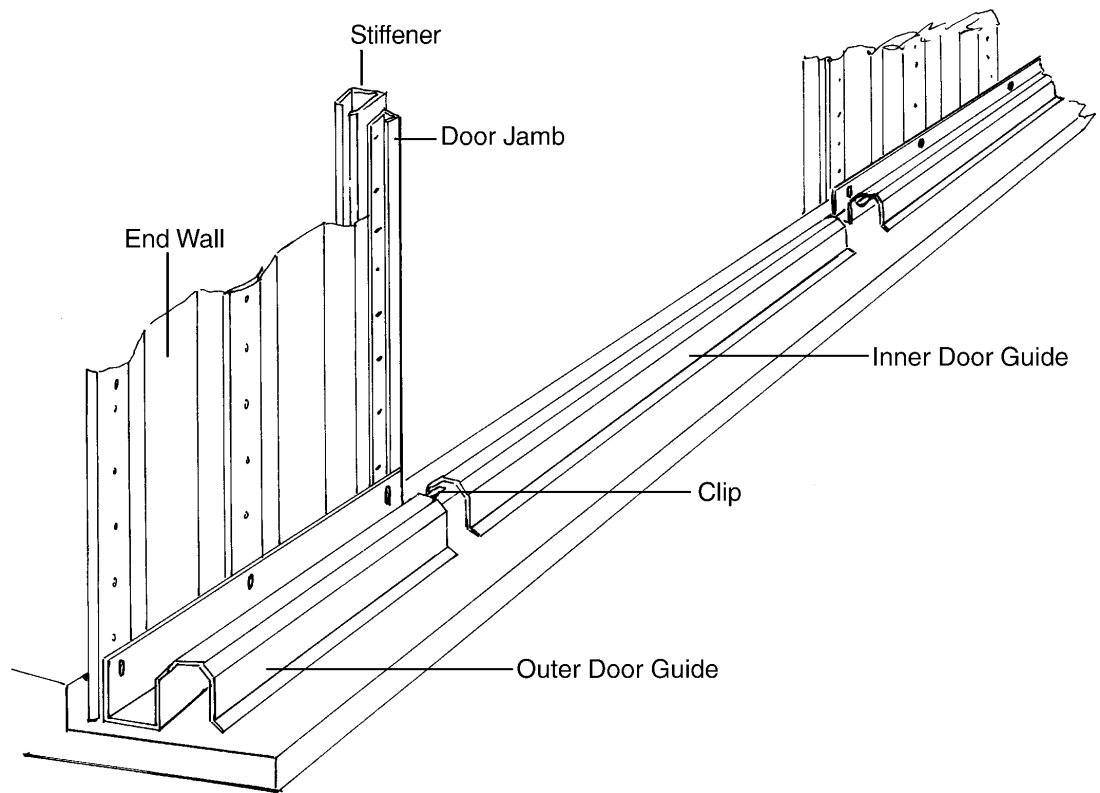


ILLUSTRATION X.A