



Welcome to Our Family

Congratulations on your investment in an arch-type steel building from U.S. Buildings. Thousands of owners, just like you, have chosen our buildings because they understand the importance of quality, undeniable strength, and ease of construction. Your building has been designed and engineered with these features in mind.

Before you start construction of your building please read through your manual and note any questions you may have, then if you have any questions call our customer service department immediately so we can assist you.

1-800-463-6062

Once you are ready to start, follow the instructions and you will be surprised at how easy it was. Once again thank you for your business.

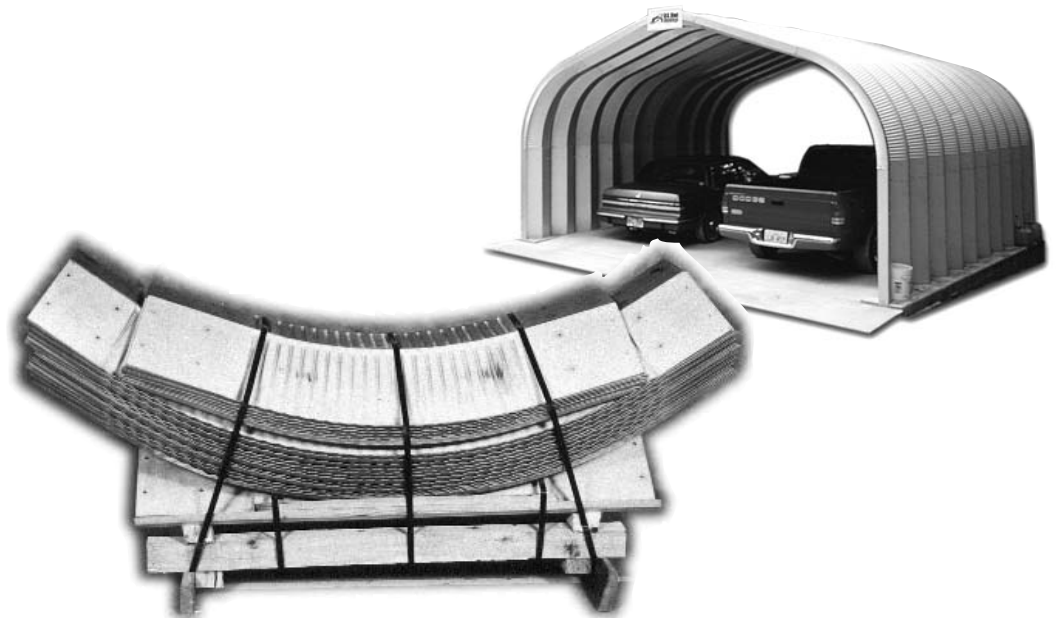

Inside Support is Recommended When Erecting Your Building.

Scaffolding with supports for all models A, S, Q, T, & R

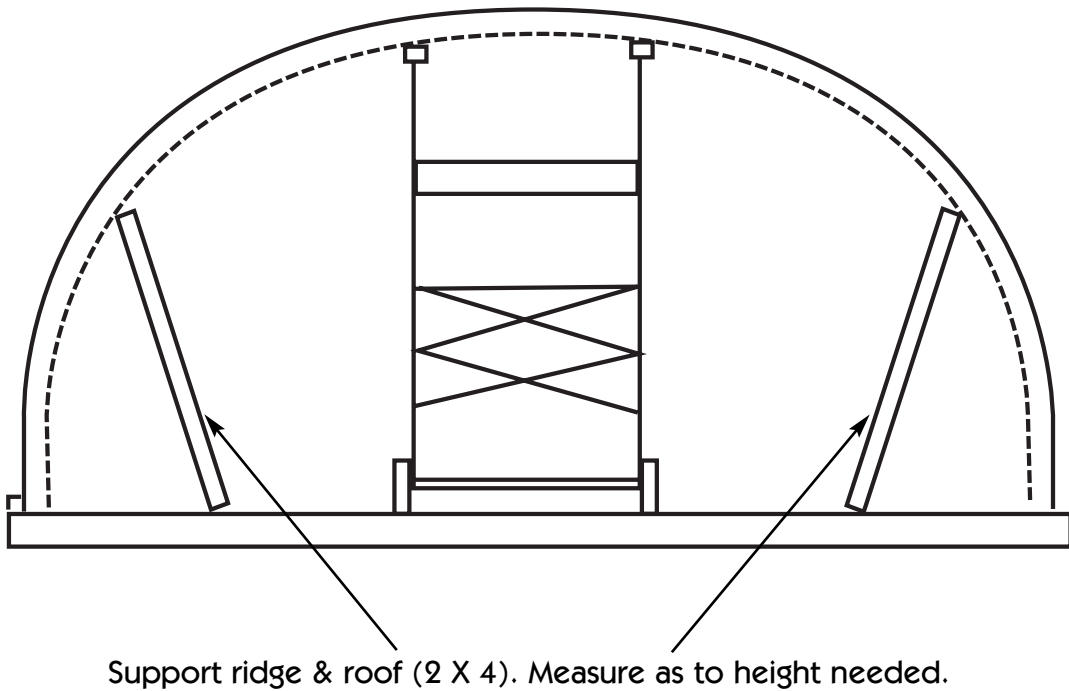

Supporting the building when raising the arches is recommended for the following reasons:

1. Helps maintain the true peak height.
2. Helps prevent sagging caused by downward force.
3. Helps with the lining of the bolt holes.

Table of Contents

Your Building Model	4
Storage Recommendations	4
Tools and Equipment	5
Foundation Recommendations	6
(Your foundation Drawings, Clearance Profiles and Accessories Installation Instructions will be inserted between pages 4 and 5.)	
Assembling The Arches	7
Preparing To Raise The Arches	8-9
Constructing The Arches	10
Strapping The Arches	11
Completing The Arches	12
Assembling Curved Angels	13
Installing Endwalls	14-15
Grouting Your Building	16

Cautions, Notes and Tips

You'll find this information through your manual:



Cautions must be observed to avoid possible damage to your building.



Notes contain important information about your building.



Tips contain additional hints for a great building.

Your Building Model

Your building model is a
U.S. Buildings Model _____.



IMPORTANT

U.S. Buildings highly recommends you purchase construction insurance before you assemble your building. **Your building does not reach its full capacity until it is fully assembled and grouted into the footing.** If you are using our channels, **the building must be fully attached to the channel and the C Channel must be grouted.** Sudden changes in weather can cause damage during construction, therefore construction insurance can help protect you from damage at a reasonable cost. U.S. Buildings is not liable for any damage to building property or persons during the construction process.

Your order #

Storage Recommendations

Your building and its components were inspected thoroughly when it left the factory. If you must store your building before you begin construction, the following guidelines from the steel manufacturer should be followed:

Inside

- A. Store in a dry vented area.
- B. Cut the strapping and separate panels to allow air to move around each piece.
- C. Never allow moisture on, or in between, any steel parts before construction.

Outside

- A. Cut the strapping and separate panels with dry pieces of wood.
- B. Separate endwall bundles.
- C. Keep all parts off the ground.



A special passive oil has been applied to the steel for added protection during storage. The oil will protect your steel for up to 30 days. Inside storage is preferred over outside storage.

Tools

The tools listed below include everything you'll need for the proper construction of your U.S. Building. These materials are not supplied with your building.



You may not need all the tools listed. However, if your building is specially customized, you may require additional tools.

TOOLS:

- Hard Hats and Work Gloves (working gloves protect against sharp edges)
- 2 Tape Measures (50 ft./100 ft., and 10 ft.)
- Level
- 1/2" and 9/16" Wrenches
- Cutting Shears (manual or electric), Handsaw, Hacksaw
- Rope (100 ft. Length)
- 2 "S" hooks
- Electric Impact Gun
- 1/2" (6) Point Socket
- Pliers
- Power (circular) saw, Keyhole saw, saber saw
- Electric drill, 3/8" minimum, variable speed
- Drill bits, 3/8" for sheet metal
- Extension Ladder
- Scaffolding and Stepladders & Jacks



Your Building Profile and Foundation Drawings should be inserted between pages 4 & 5, if not contact customer service immediately.

Foundation Recommendations

Because there are so many different local soil and loading conditions, **we can't recommend or be responsible for the design.** Most people hire a local contractor who is familiar with the local area and conditions. The following foundation notes have been prepared to assist you and your contractor, assuring you a solid, well-built foundation. Again, since many local factors affect the design of your foundation, **the following dimensions are for illustration only.** Designing the best foundation for your building based on local codes is where a civil engineer will be of valuable assistance.



TROUGH



Trough or C-Channel after grouting.



Building must be grouted immediately after all arches are stood and bolts are tightened.



Recommended concrete mix for the foundation is 3500 PSI with 1LB of fiber per yard of concrete.

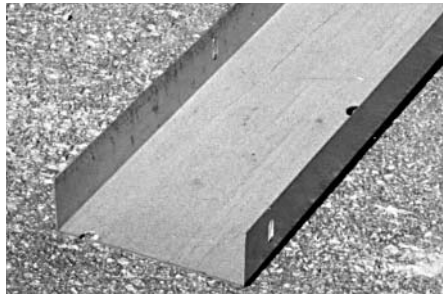

C-CHANNEL

Suggested anchor bolt pattern supplied with foundation plans.



INDUSTRIAL CONNECTOR

Suggested anchor bolt pattern supplied with foundation plans.

The foundation dimensions shown will provide your foundation engineer with everything necessary to give you a solid, sound and stable foundation.

Assembling The Arches

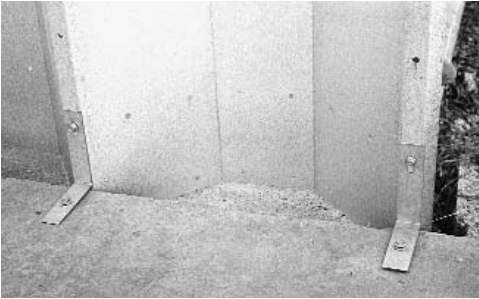

Anchor bolts or tie down brackets are not supplied with your building, but are strongly recommended. In the event of high winds during construction they will help to hold your building down and prevent your building from lifting out of the foundation. Anchor bolts and tie down brackets are to be used as *temporary support only* as arches are stood. **TIE DOWN BRACKETS ARE NOT A SUBSTITUTE GROUTING** for permanent support. You must grout your building to reach its full wind and snow load capacity. These are available at most local hardware retailers or can be purchased from your U.S. Buildings sales representative. **Again, we highly recommend construction insurance.**



It is recommended that you put anchor bolts every 24" at the outside peak of each arch, on the 5" portion of your foundation (see illustration). 1/2" x 5" wedge type anchors are recommended.

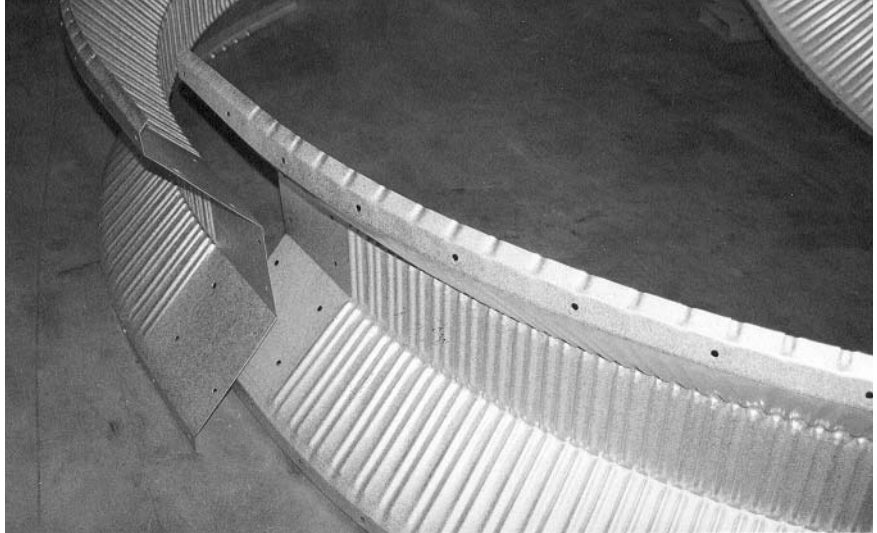

Simply build the arches on ground, 80% of the work will be done on the ground.



Bolts in arches - **finger tight only.**

Preparing To Raise The Arches



Wind Direction

Place arches on the ground ready to stand away from prevailing winds.



Set up scaffolding platform in a way to provide you a raised standing area to easily pull up your arches. (scaffolding usually can be rented locally)



Scaffolding

Preparing To Raise Arches (continued)



It is essential to place support jacks (some rental stores refer to these as house levelers) upside down into the 4 corners of scaffolding to help in supporting and maintaining the proper building height during the construction process.



Adjustable Scaffolding Jacks. After 1st, 2nd and 3rd arches are stood, move your scaffolding forward 1 arch at a time until building is completed.



Raising the arches is the only time in the construction of your building that may require additional assistance.

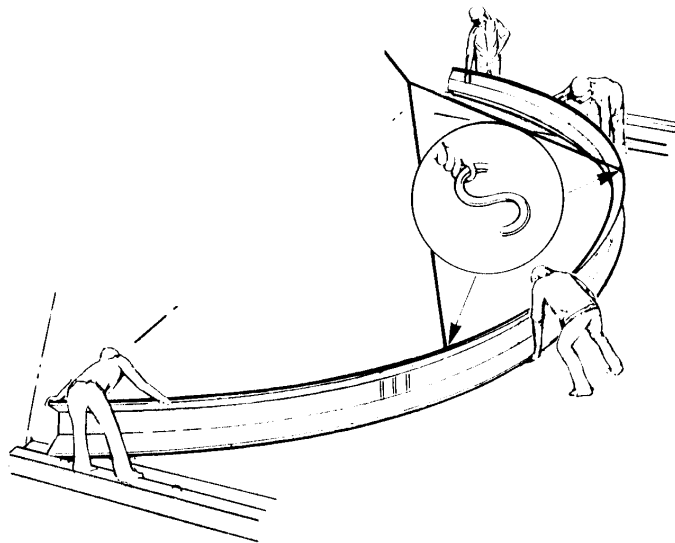

Raising Arches. Place S-Hooks approximately 6-8 bolt holes to the right and left of center of arch to attach rope. (Support arches as shown above, to correct height as noted in your Profile Insert. The hole location changes depending on the height of your scaffold, and the number of men you have.) With the ropes and hooks in place, and one or two men on each corner to guide the arch into the trough the first arch is pulled to an upright position.

Constructing The Arches



Raising Arches.

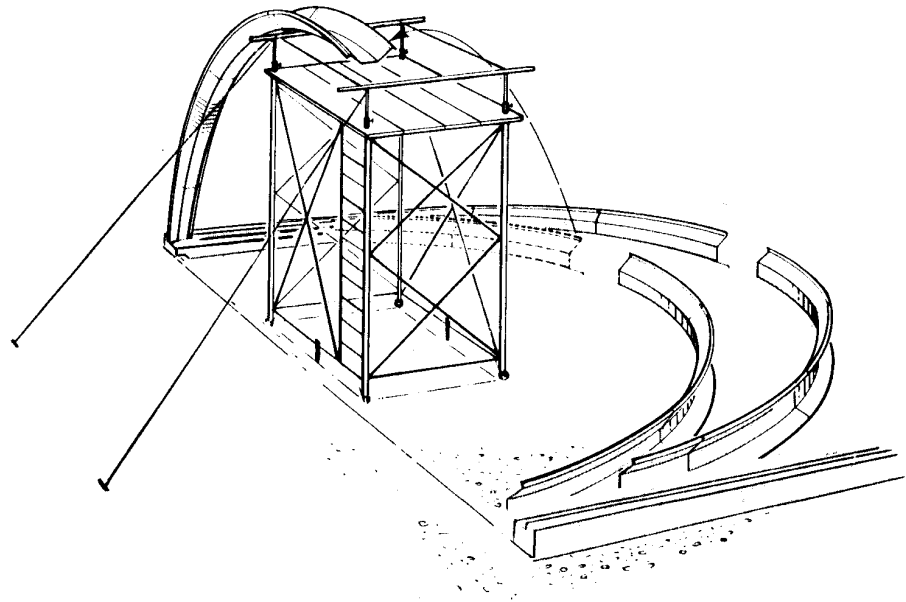

Half Arch Method. For buildings 40' wide and larger the Half Arch Method of construction is recommended.



If you live in a heavy snow area we recommend that you leave the strapping on your building.

Strapping The Arches



Strapping arches is essential in keeping your building the proper length and height. Place strapping centered on 1st curved panel as shown above and in Illustration A, number 1 below.



Strapping is supplied with your building and must be used to maintain a 24" center to center.

Three of these straps should be bolted into the arches, one on each side and one at the peak as the construction proceeds. (shown here)

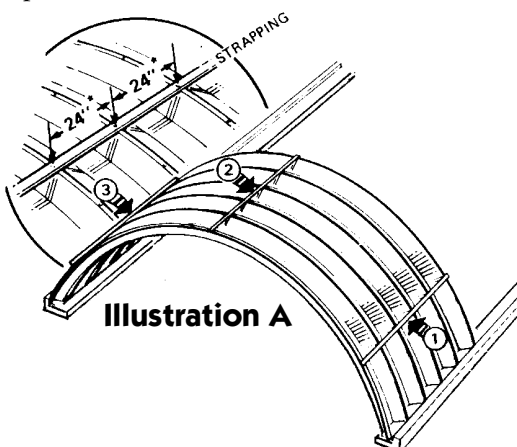

You are supplied with 6 to 8 pieces of strapping you must move it forward during construction to keep building on 2 foot centers. After construction place 3 pieces of strapping on each end of the building as shown in Illustration A.

Completing The Arches



Arches Stood.



After standing your arches with all bolts finger tight and strapping on, square and plumb your building. At this time tighten all bolts starting with the bottom straight panel working upwards.



It is important to keep your drift pins in place 2 bolt holes ahead while inserting bolts.

Assembling Curved Angles

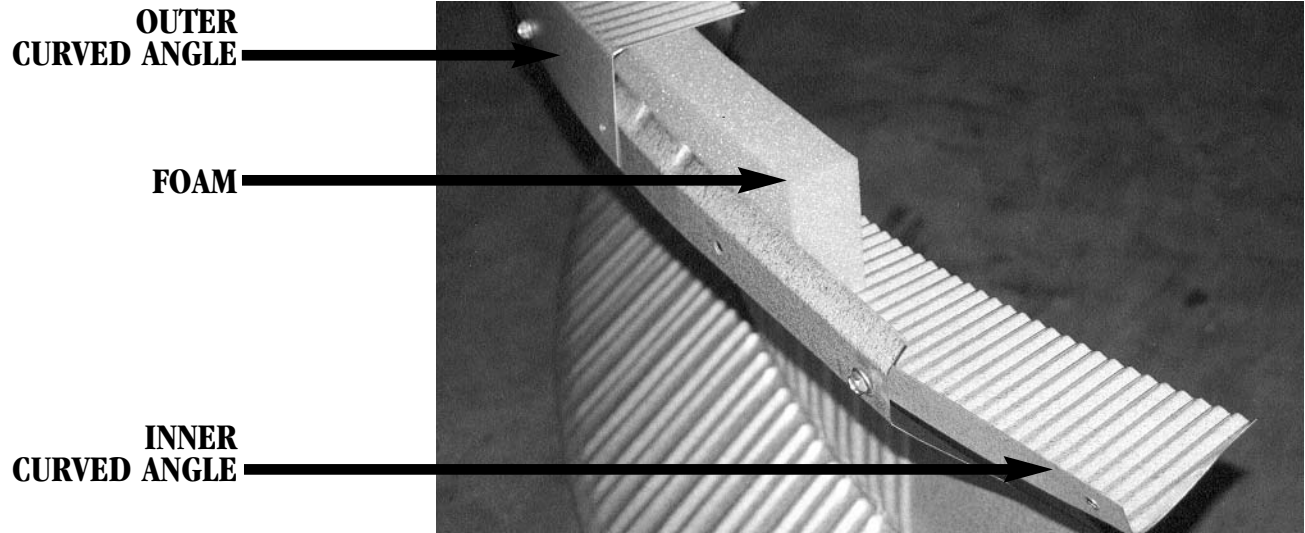

The Curved Angles are put on the outside of the 1st and last arch to accept the endwalls. **(A Models overlap 1 bolt hole, S and Q Models overlap 2 bolt holes.)**

The outer curved angle is now installed on top of the arch and the inner curved angle, bolts to the underside of the arch.



It is recommended that you lay your endwall panels out near your building in order to assure that they go into the proper location.

Installing Endwalls



Solid endwall in progress.



It is important to begin assembling your solid endwall from the center and work toward the outside walls. A mark should be placed on the concrete at your center point and the center bolt of your first panel should be lined up here. Panels should be centered 18" out to the left and right.

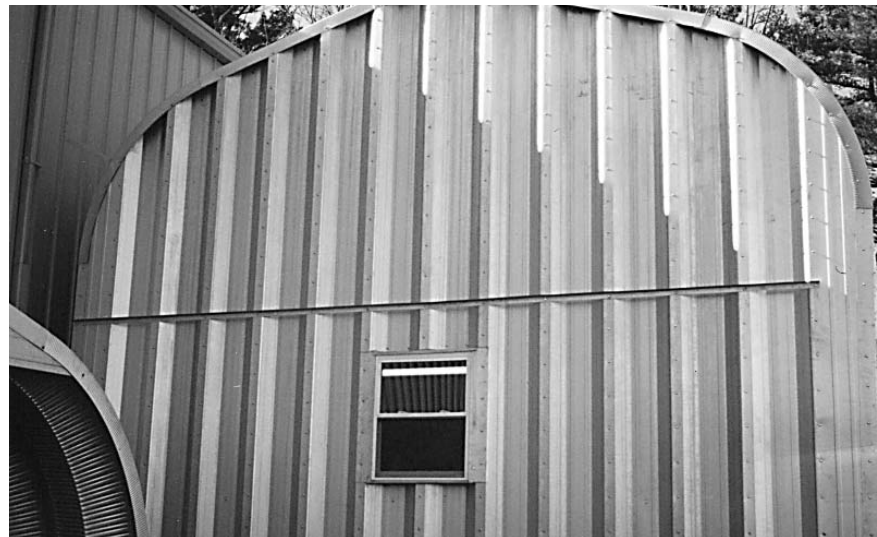

Strapping is punched on 18" centers to accommodate the bolts in the endwalls. It is essential to use this strapping so the endwall lines up and the corner flat panels fit properly.

Solid endwall completed.



Installing Endwalls With Opening

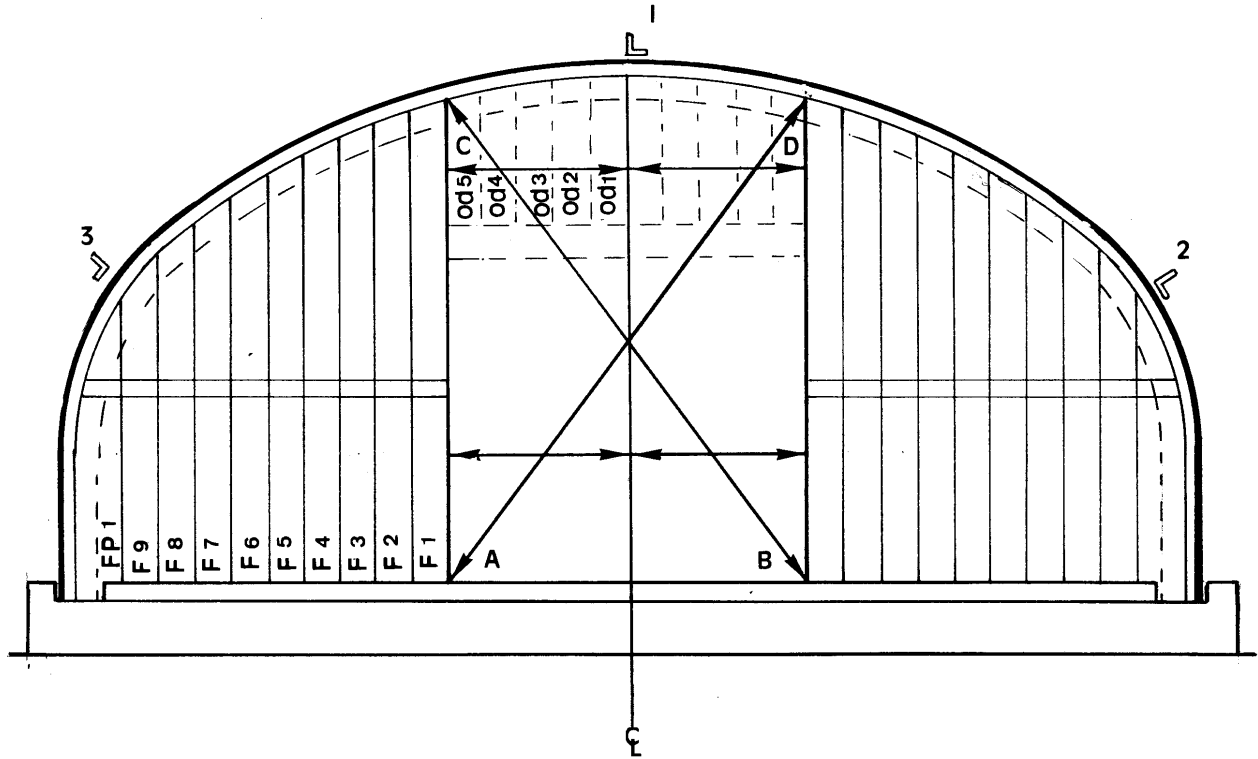

It is important to begin assembling your endwall with panels marked F1 and work toward the outside walls. Opening should be squared and center marked on concrete. Begin with Panels marked F1, once panels are installed left and right of opening install the shorter panels over door beginning with panel marked OD1.



Endwall with opening completed.

Grouting Your Building



Recommended mix for the grouting is 5000 PSI cement and sand (Portland non-acidic) mix only (no stone). Grouting of the building should be inside as well as the outside. Mix 1 part cement 2 1/2 parts sand. Some areas may require variable mixtures.

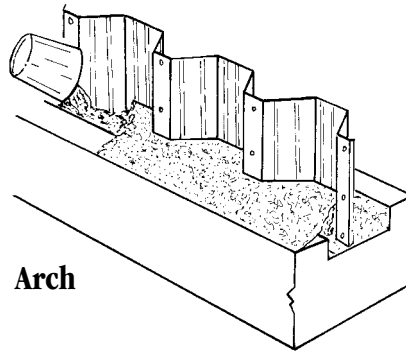

Arch

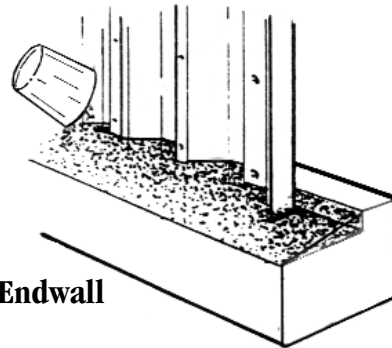

Endwall

When grouting your building make sure to use a 1" slope to allow water to run away from the building.

The steel panels are protected by a coat of special oil. This oil may affect the bond between the steel and the grout, so you must clean the panels by wiping with a suitable solvent such as varsol. Steel is also sensitive to the chemical reaction of concrete during the curing period, therefore, the steel mill will not cover their warranty unless a thin coating of lacquer or varnish is applied to the panel before grouting.

Grout both inside and outside of arches and endwalls. This will properly secure your building to its foundation. Also, you should place a caulk seam where grout meets steel to produce a water resistant seam.



Your building and endwalls MUST be grouted immediately after your arches are raised and tightened. Failure to do so WILL cause the building to collapse.

Important: Grout mixture must not contain any corrosive substances, such as calcium chloride. This will result in steel corrosion. Grout is typically one part portland cement and 2 1/2 parts sand.



Grouting completed.